

Reed Switches Applications

REED SWITCHES

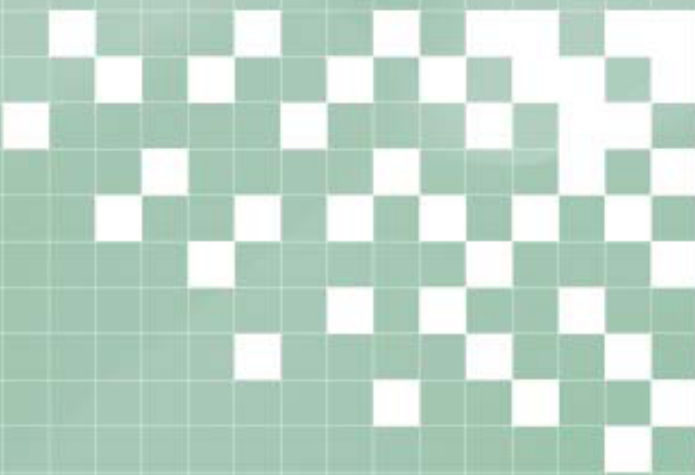



- All specifications in this catalog and production status of products are subject to change without notice. Prior to the purchase, please contact NEC TOKIN for updated product data.
- Please request for a specification sheet for detailed product data prior to the purchase.
- Before using the product in this catalog, please read "Precautions" and other safety precautions listed in the printed version catalog.

PRECAUTIONS TO BE TAKEN WHEN USING REED SWITCHES AND APPLICATIONS
(Please read these precautions before using our products)

1. Before using our products or designing a system using our products, please read the "Precautions To Be Taken When Using Our Products" section in this catalogue and the section entitled "Equipment with which our products are used" (such as a level of quality) on the last page of the catalog.
2. The main failures with reed switches and applications are open-circuit, short-circuit, and faulty operation. For details, please refer the section entitled "Precautions To Be Taken When Using Our Products" in the catalogue.

 When using the products, systems should be carefully designed to ensure redundancy and to prevent faulty operation, allowing for the occurrence of failures.
3. Use the products after checking the working conditions and rated performance of each of the reed switches and applications

ISO 9001 QS 9000	ISO 14001
	
<small>NEC TOKIN CERAMICS CORP. REGISTERED TO QS-9000 & ISO 9001 CERTIFICATE NO:A13033</small>	<small>JQA-E-90094</small>



- All specifications in this catalog and production status of products are subject to change without notice. Prior to the purchase, please contact NEC TOKIN for updated product data.
- Please request for a specification sheet for detailed product data prior to the purchase.
- Before using the product in this catalog, please read "Precautions" and other safety precautions listed in the printed version catalog.

CONTENTS

Reed Switches	4
Surface Mounting Type Reed Switches	8
Proximity Switches NRS Series	10
Precautions to be Taken when Using Reed Switches/Proximity Switches	13
Twin Reed Switch Type Safing Sensor High Stand Type : TMSD-H**51D	18

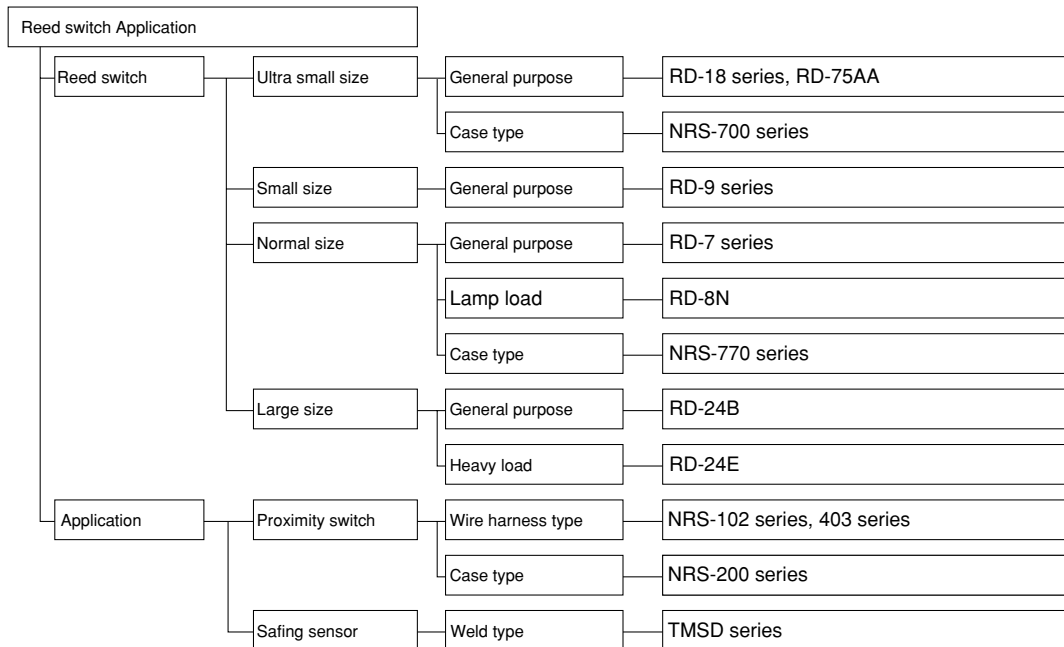

● All specifications in this catalog and production status of products are subject to change without notice. Prior to the purchase, please contact NEC TOKIN for updated product data.
 ● Please request for a specification sheet for detailed product data prior to the purchase.
 ● Before using the product in this catalog, please read "Precautions" and other safety precautions listed in the printed version catalog.

Reed Switches

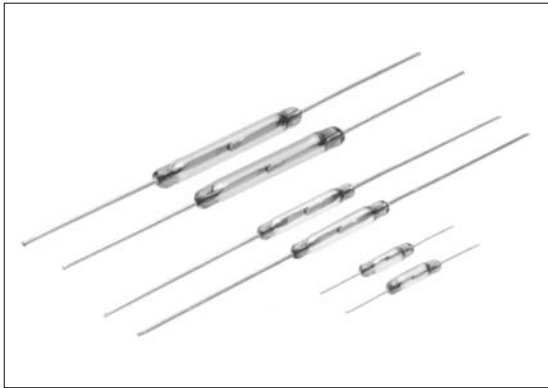

Outline

NEC TOKIN provides a wide range of reed switches for minute-load to high-power switching purposes. The reed switches are available in two types, i.e., a reed switch having ruthenium-plated contacts and a reed switch having rhodium-plated contacts. Please choose the optimum reed switch best-suited to your intended applications from a wide selection of reed switches.

Features

- **Compact and Lightweight**
The reed switches are suitable for use as a compact and lightweight magnetically responsive switch, thereby rendering equipment smaller.
- **Ambient Resistance**
Contacts of the reed switch are encapsulated in a glass tube together with inert gas (nitrogen gas), which protects the reed switch from the effects of the exterior environment, for example, gas, dust, or moisture in the atmosphere.
- **Relatively stable characteristics are ensured from low to high temperatures.** The reed switches are usable over a wide variety of temperatures.
- **High Reliability**
Considerably high reliability is assured as a result of the adoption of NEC TOKIN's unique contact processing technique.
- **High-speed Operation**
Since the reed switch operates at high speed, it is easy to interface with a transistor or an IC.
- **Long Life**
A long-life reed switch without mechanical friction is implemented as a result of its simple structure.
- **Extensive Applications**
When used in combination with a permanent magnet, the reed switch finds extensive application in switching and sensing.



Structure and Principle of Operation

A reed switch encapsulated in a glass tube has two ferromagnetic reeds which face each other with a given contact clearance between them, as shown in diagrams on the right. The glass tube is filled with nitrogen gas to prevent the activation of the contacts, thus providing improved reliability and extended life.

Upon receipt of a magnetic field from the outside in the axial direction of the reed switch, the reeds of the reed switch are magnetized. The free opposite ends of the reeds attract each other and come into contact with each other, to close the circuit. When the magnetic field is removed, the circuit opens by means of the resiliency of the reeds.

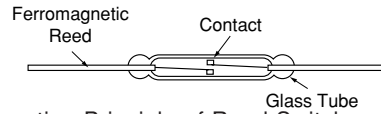

● Operating Principle of Reed Switch

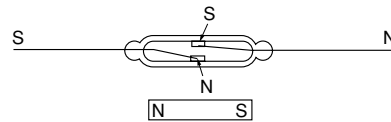

Contact Material

- Ruthenium (Ru) plated contact
Ruthenium-plated contacts developed by NEC TOKIN's unique technique are made of a very hard material having with a high melting point. The contacts are resistant to mechanical friction and heat generation, and they have excellent anti-sticking performance.
- Rhodium (Rh) plated contact
Power reed switches what are susceptible to relatively large consumption employ Rh-plated contacts, which results in extended life of the reed switches (compensating for contact consumption).

Characteristics of Contact Material

Items	Ru (Ruthenium)	Rh (Rhodium)	Au (Gold)
Atomic Weight	101	103	197
Melting Point (K)	2,523	2,233	1,338
Boiling Point (K)	4,173	4,000	2,983
Density (g/cm ³)	12.1	12.4	19.3
Specific Heat (J/g·K) 0°C	0.234	0.238	0.128
Hardness (HV)	220	100	25
Tensile Strength (kgf/mm ²) (N/m ²)	50.0 490×10 ⁶	54.9 538×10 ⁶	13.5 132×10 ⁶

Types and Applications

When used in combination with a permanent magnet, the reed switch finds extensive applications in which it provides switching and sensing capabilities.

● Construction of Reed Switch

Type	Part No.	Applications
General purpose	RD-7AA/ 7B/24B NRS-771	For general control purposes (about 10W)
High power	RD-24E	Heavy load (50W)
Lamp load	RD-8N	Direct switching of a 3.4W lamp (for surge current use)
Compact	RD-9A/9B	For general control purposes (about 5W)
Ultra compact	RD-18A/18B /75AA NRS-701	Light load

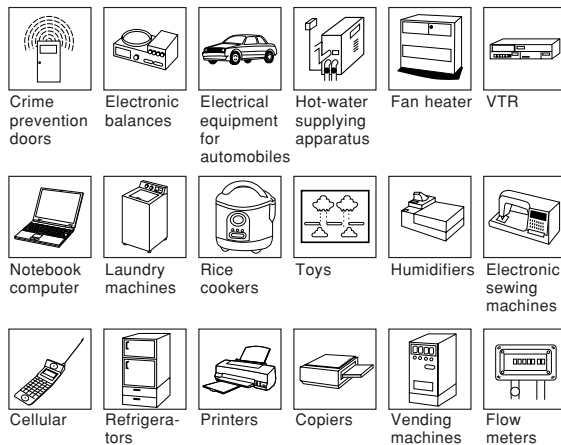

- All specifications in this catalog and production status of products are subject to change without notice. Prior to the purchase, please contact NEC TOKIN for updated product data.
- Please request for a specification sheet for detailed product data prior to the purchase.
- Before using the product in this catalog, please read "Precautions" and other safety precautions listed in the printed version catalog.

Reed Switches

(The switches are arranged in ascending order of glass tube length.)

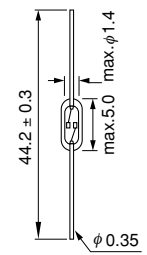
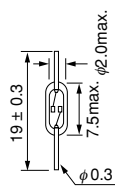
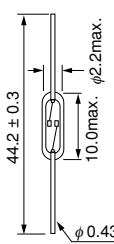
Items	Types	RD-75AA	RD-18A	RD-18B	RD-9A	RD-9B	
Outer Dimensions (mm)							
Pick up Ampereturns (A)		10 to 20	15 to 30	10 to 30	10 to 30	10 to 30	
Drop-out Ampereturns (A) min.		1	5	5	35% of Pick up	3	
Operating Time (ms) max.		0.5	0.5	0.5	1	0.5	
Release Time (ms) max.		0.05	0.05	0.05	0.05	0.05	
Bounce Time (ms) max.		0.5	0.5	0.5	0.5	0.5	
Contact Rating	Maximum Switching Power (W)	3	1	1	5	5	
	Maximum Switching Voltage (VDC)	20	30	30	100	100	
	Maximum Switching Current (A)	0.2	0.1	0.1	0.5	0.3	
	Maximum Carrying Current (A)	0.3	0.3	0.3	0.7	0.5	
Contact Resistance (mΩ)		200	200	250	150	200	
Withstand Voltage (VDC)		100	200	200	200	200	
Insulation Resistance (Ω)		10 ⁹ (at an application of 100VDC)					
Shock and Vibration Resistance (m/s ²)		Fracture 294	Faulty Operation 98 (Fracture 490)				
Operating Temperature Range (°C)		-40 to +125					
Reed Resonant Frequency (kHz)		13.7	10	10	7.2	7.2	
Life Expectancy (operations)	Mechanical Life Expectancy	1×10 ⁸					
	Electrical Life Expectancy	5VDC, 10mA, and Resistive Load	1×10 ⁷	1×10 ⁷	1×10 ⁷	5×10 ⁷	5×10 ⁷
		Others					
Contact Material		Rh (Rhodium)	Rh (Rhodium)	Ru (Ruthenium)	Rh (Rhodium)	Ru (Ruthenium)	
Characteristics and Applications		Ultra-compact light load			Compact, and general control purposes		
NEC TOKIN's Standard Coil		N-104			N-103		
UL File No.		-	-	-	-	-	

*Pre-soldering on terminals are lead-free (Sn100%)



- All specifications in this catalog and production status of products are subject to change without notice. Prior to the purchase, please contact NEC TOKIN for updated product data.
- Please request for a specification sheet for detailed product data prior to the purchase.
- Before using the product in this catalog, please read "Precautions" and other safety precautions listed in the printed version catalog.

Surface Mounting Type Reed Switches



Outline

These reed switches are Surface-mounting type and Suited for automatic mounting.

Applications

When used in combination with a magnet, the reed switch finds extensive applications in which it provides switching and sensing capabilities.

- Cellular phones
- Car electronics
- OA electronics
- Home electronics

Features

- Suited for automatic mounting
- Can be soldered using reflow
- With the NRS-700series, its glass tube is covered with a case, making it easy to handle.

Shapes and Dimensions

● RD Series

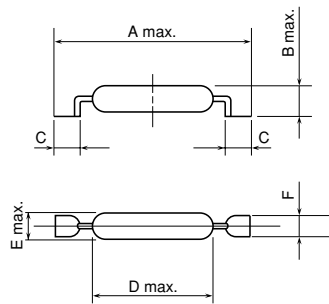

Model	A	B	C	D	E	F
RD-18B-S003	12.5	2.3	1.4	7.5	2.0	1.2
RD- 7B-S002	19.9	2.5	(1.8)	14.0	2.2	1.6

● NRS Series

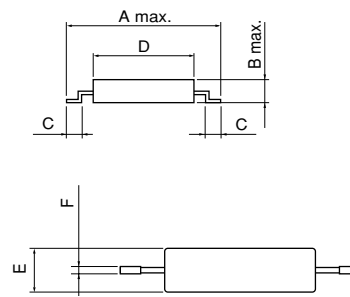

Model	A	B	C	D	E	F
NRS-701	13.0	2.2	1.2	8.3	2.4	0.4
NRS-771	24.0	3.0	1.6	17.0	3.0	0.6

Numbering System

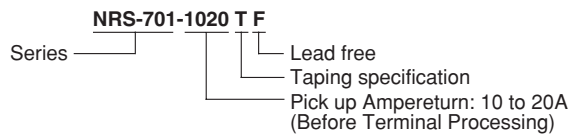

*Pre-soldering on terminals are lead-free (Sn100%)



- All specifications in this catalog and production status of products are subject to change without notice. Prior to the purchase, please contact NEC TOKIN for updated product data.
- Please request for a specification sheet for detailed product data prior to the purchase.
- Before using the product in this catalog, please read "Precautions" and other safety precautions listed in the printed version catalog.

Specifications

Items		RD-18B	RD-7B	NRS-701	NRS-771
Maximum Switching Power	(W)	1	10	1	10
Maximum Switching voltage	(VDC)	30	100	30	100
Maximum Switching Current	(A)	0.1	0.5	0.1	0.5
Maximum Carrying Current	(A)	0.3	1.0	0.3	1.0
Contact Resistance	(mΩ)	250	150	300	200
Operating Time	(ms) max.	0.5	0.5	1.0	1.0
Release Time	(ms) max.	0.05	0.05	0.1	0.1
Withstand Voltage	(V.DC)	200	200	200	200
Insulation Resistance	(Ω)	10 ⁹ (at 100VDC)		10 ⁷ (at 100VDC)	
Life Expectancy	5VDC, 10mA and Resistive Load	1×10 ⁷	5×10 ⁷	1×10 ⁷	5×10 ⁷
Operating Temperature Range	(°C)	-40~+125		-40~+85	
Weight	(mg) max.	40	90	80	250

Reel Tape Dimensions

Tape Dimensions

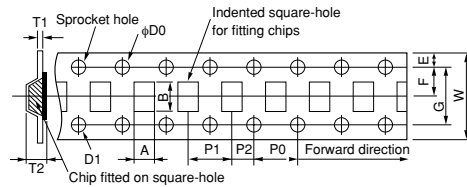

Reel Dimensions

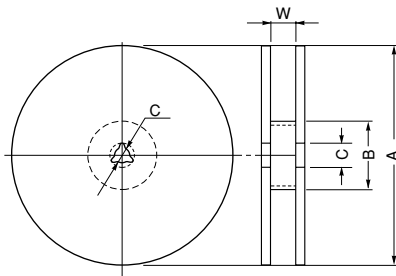

(mm)

Type	RD-18B	RD-7B	NRS-701	NRS-771
A	2.0	4.0	2.7	3.3
B	13.2	20.3	16.0	32.0
W	24.0	32.0	24.0	44.0
F	11.5	14.2	11.5	20.2
E	1.75	1.75	1.75	1.75
G	-	28.4	-	40.4
P1	8.0	8.0	8.0	8.0
P2	2.0	2.0	2.0	2.0
P0	4.0	4.0	4.0	4.0
D0	1.55	1.55	1.55	1.55
D1	-	1.55×1.75	-	1.55×1.75
T1	0.3	0.3	0.4	0.4
T2	(3.0)	(3.0)	(3.2)	(4.2)

(mm)

A	250	330	330	382
B	100	80	80	80
C	13.0	13.0	13.0	13.0
W	24.5	33.5	24.5	45.5

Standard number of Packages (piece/reel)	
RD-18B	1,000
RD-7B	2,000
NRS-701, 771	2,000

Example for operation characteristics

Driving Area by Means of Ferrite Magnet 5×5×7 (NRS-701)
Values in the graph indicates reed switch's pick up ampereturns.

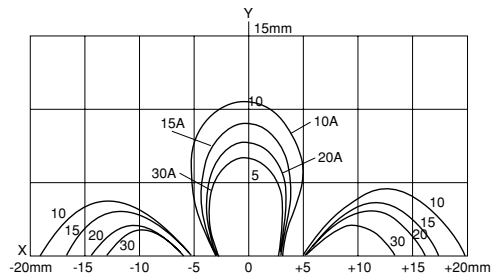
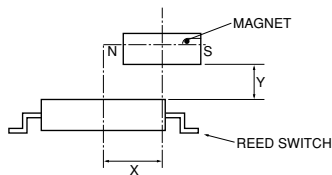

- All specifications in this catalog and production status of products are subject to change without notice. Prior to the purchase, please contact NEC TOKIN for updated product data.
- Please request for a specification sheet for detailed product data prior to the purchase.
- Before using the product in this catalog, please read "Precautions" and other safety precautions listed in the printed version catalog.

Proximity Switch NRS Series



Outline

With a built-in reed switch, NEC TOKIN's proximity switches are compact, lightweight and highly reliable while realizing high economy. Used in combination with permanent magnets, these switches find wide use in switching, sensing and other applications.

Features

- Compact and Lightweight
The proximity switches are suitable for use as a compact and lightweight magnetically responsive switch, thereby rendering equipment smaller.
- Ambient Resistance
Contacts of the proximity switch are encapsulated in a glass tube together with inert gas (nitrogen gas), which protects the proximity switch from the effects of the exterior environment, for example, gas, dust, or moisture in the atmosphere.
- Simple Circuit for design
The proximity switches are usable for progress of the reliability, durability and maintenance in the electronic machine.

Applications

- Position detection (door switches, float, etc)
- Rotation detection

Performance (NRS-102/NRS-403 Series)

Items	Types	Performance
Contact form		1 Form A
Maximum Switching Power	(W)	10
Maximum Switching Current	(A)	0.5
Maximum Switching Voltage	(V.DC)	100
Withstand Voltage	(V.DC)	200
Ambient Temperature	(°C)	-20~+80
Contact Resistance	(mΩ)max.	500
Electrical Life Expectancy		12V.DC, 5mA resistive load... more than 10 million operations



- All specifications in this catalog and production status of products are subject to change without notice. Prior to the purchase, please contact NEC TOKIN for updated product data.
- Please request for a specification sheet for detailed product data prior to the purchase.
- Before using the product in this catalog, please read "Precautions" and other safety precautions listed in the printed version catalog.

Shapes and Dimensions

● NRS-102Series

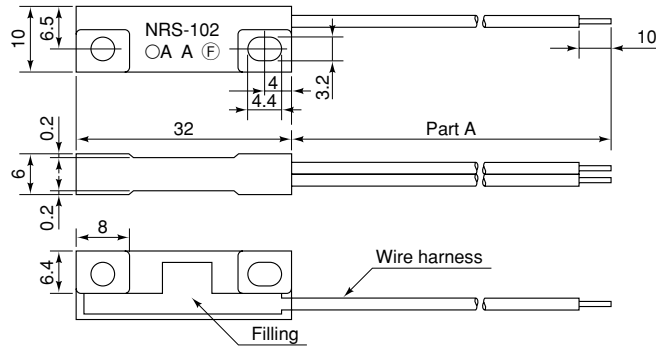

● NRS-403Series

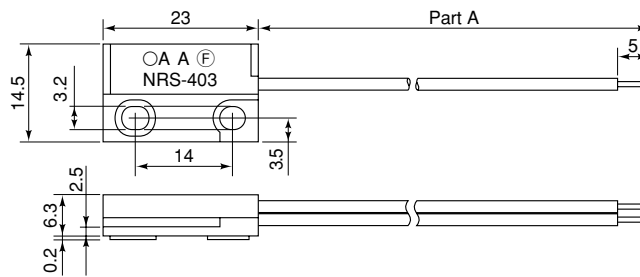

(mm)

Numbering System

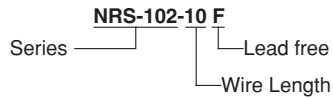

*Lead-free (Sn100%)

Number

Number	Contact Resistance (included conductor resistance)	*Wire Length (Part A) [cm]
NRS-102-**	500(mΩ)max.	10,20,30,40,50,60,70,80,90,100
NRS-403-**	500(mΩ)max.	10,20,30,40,50,60,70,80,90,100

*We append the designated connector on demand.
 **M4 thread fastening NRS-103 series also available.



- All specifications in this catalog and production status of products are subject to change without notice. Prior to the purchase, please contact NEC TOKIN for updated product data.
- Please request for a specification sheet for detailed product data prior to the purchase.
- Before using the product in this catalog, please read "Precautions" and other safety precautions listed in the printed version catalog.

Operation range

Operation ranges of the proximity switch driven by the ferrite magnet are shown below. In the measurement, Y denotes a distance between the side planes of the proximity switch and the permanent magnet, and X denotes a distance of parallel displacement of the permanent magnet while keeping the distance Y.

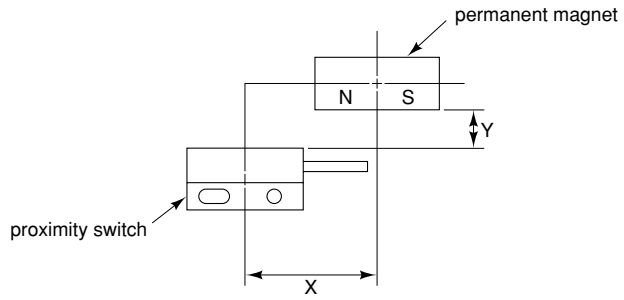

Operation range by Ferrite Magnet 5×5×7 of NRS-102

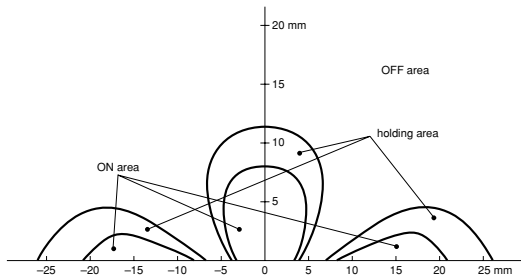

Operation range by Ferrite Magnet 5×5×7 of NRS-403

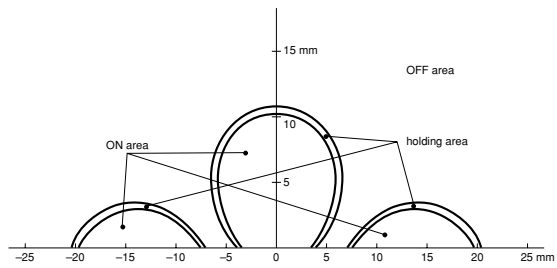

- All specifications in this catalog and production status of products are subject to change without notice. Prior to the purchase, please contact NEC TOKIN for updated product data.
- Please request for a specification sheet for detailed product data prior to the purchase.
- Before using the product in this catalog, please read "Precautions" and other safety precautions listed in the printed version catalog.

Precautions to be Taken when Using Reed Switches/Proximity Switches

Processing of Terminal

The size of the product on which the reed switch is mounted determines the installation method and positioning. (See Figure 1 for example.)

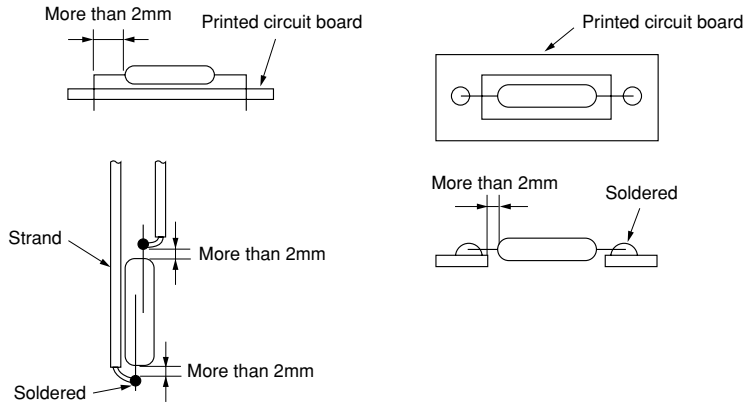

Fig. 1 Example of Mounting of Reed Switch

- Notes
- 1) The relative position between a reed switch contact and a magnet becomes important when the reed switch is actually used. Naturally, a method which makes it easy to accurately position contacts of the reed switch is preferable.
 - 2) Position the reed switch with respect to the end face of the reed switch terminal. A glass tube that has a poor axial accuracy can not be used for reference.
 - 3) When bending or cutting the terminals of the reed switch, please bend or cut the terminals after having fixed them using pads so as to prevent force from being exerted on the sealed portion, as shown in Fig. 2.
 - 4) To protect a sealed portion of the glass tube, the glass tube should be spaced more than 2mm apart from an area where the terminals are bent or cut (Fig. 2).
 - 5) The terminals of the reed switch form a part of a magnetic circuit. If the terminals are cut, the pick up and the drop-out value increase, as shown in Fig. 3. Please note that similar results will be expected even if the terminals are bent.

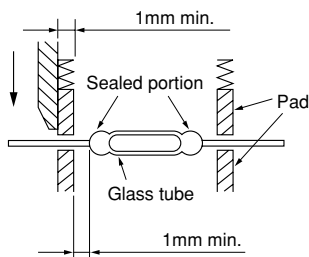

Fig. 2 Example of cutting of terminal

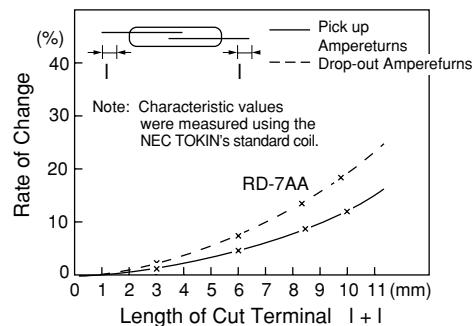

Fig. 3 Example of variations in pick-up and drop-out values resulting from cutting of terminal

- 6) To protect sealed portions of the glass tube, the terminals should be soldered while being spaced at least 1mm or more, preferably 2mm or more, away from the glass tube.



● All specifications in this catalog and production status of products are subject to change without notice. Prior to the purchase, please contact NEC TOKIN for updated product data.
 ● Please request for a specification sheet for detailed product data prior to the purchase.
 ● Before using the product in this catalog, please read "Precautions" and other safety precautions listed in the printed version catalog.

Fixing of Terminal

● When the terminals of the reed switch are fixed to a printed wiring board, it is recommended that a clearance of more than 2mm be ensured between the sealed portion and an area of the terminal to be fixed, in order to protect the glass tube from mechanical force, as shown in Fig. 4. Further, please do not bring solder into direct contact with the sealed portions of the glass tube, in order to prevent cracks or gas leakage from the sealed portions. It is also recommended that soldering of the terminals be carried out at a temperature of less than 250°C and be completed within 3 sec.

(1) When the terminals of the reed switch are welded, one terminal may become lifted off in relation to the other terminal, as shown in Fig. 5, thereby exerting force on the sealed portions of the glass tube. To prevent this problem, please weld the terminals under appropriate conditions (e.g., welding voltage and current, and applied pressure).

Further, it is expected that a magnetic field developed as a result of the welding current will cause the contacts to become close, which in turn permits the flow of the welding current into the contacts of the reed switch. The circulation of the welding current to the contacts must be prevented.

(2) When the reed switch is mounted on a printed circuit board, the printed circuit board should be made of a material which is less prone to deformation (resulting from, for example, thermal expansion or moisture absorption) so as to prevent bending stress, which is caused by warping the printed circuit board, from acting on the sealed portions of the glass tube.

If deformation of the printed circuit board is expected, a reed switch with angular terminals should be used to alleviate the warpage of the printed circuit board.

(3) When the reed switch is mounted on the printed circuit board while the glass tube remains in direct contact with the printed circuit board, the glass tube may crack if the printed circuit board has large warpage. To prevent cracking, the reed switch is mounted so as to be lifted off from the surface of the printed circuit board, or the reed switch is mounted such that the terminals cross over a depression or a cutout formed in the printed circuit board, as shown in Fig. 6.

(4) When the reed switch is mounted so as to be aligned with a cutout formed in the printed wiring board, attention must be paid to the shape of the printed wiring board and mounting work so as to prevent the glass tube from running onto the printed circuit board. See Fig. 7.

(5) The cutting of the lead terminals soldered to the printed circuit board by a diamond cutter must be avoided. Otherwise the sensitivity (a clearance between the contacts) of the reed switch will change.

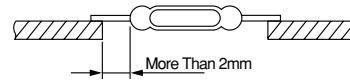

Fig. 4 Reference for terminal mounting

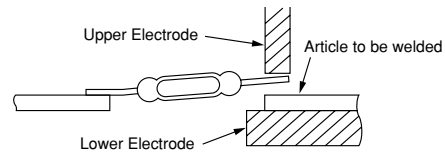

Fig. 5 Precautions to be taken when welding terminals

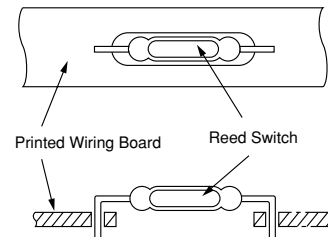

Fig. 6 Example of mounting of reed switch on warped printed wiring board

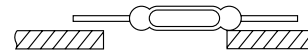

Fig. 7 Precautions to be taken when mounting reed switch on printed wiring board



Fixing of Glass Tube

- (1) If the glass tube of the reed switch is fixed using resin, the glass tube will be subject to stress resulting from contraction and expansion of the resin when the resin sets, which may result in cracks in the glass tube. Please reduce the number of points and the area of the glass tube to be fixed. (It is recommended to use fixing resin or adhesive which is flexible, and causes only a small amount of shrinkage when it sets.)
- (2) If a unit incorporating a reed switch is mounted, the unit must be prevented from warping as a result of protrusion of a filler or other foreign substances interposed between the unit and a board.

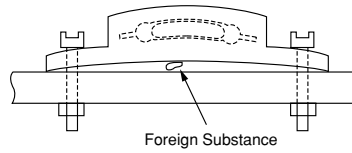

Fig. 8 Warpage in unit having built-in reed switch resulting from foreign substance between unit and board

Physical Shock

- (1) If a reed switch or a unit incorporating a reed switch is dropped from a height of more than 30cm, the characteristics (particularly the sensitivity) of the reed switch may change. Avoid physical shock.
- (2) If a large printed circuit board on which a plenty of reed switches and proximity switches are mounted is divided into several pieces by separating the circuit board along its perforations, the sensitivity of the reed switches and proximity switches may change as a result of the physical shock caused by cutting. (It is recommended to reduce the remaining perforation to as small an area as possible, and also to use a resulting unit after having checked whether or not the sensitivity of the reed switches remains unchanged).

Pick up Ampereturns

- (1) The pick-up ampere represent the sensitivity of the reed switch. These pick-up ampere have expressed in ampere (A) which is the product of the number of turns (T) and the current (A) amperes necessary for turning the contacts on (ON) when NEC TOKIN's standard coil is energized. The smaller pick-up ampere have better sensitivity.
- (2) A number "1020" in a part number such as "RD-7B-1020F" in the part No. a preset pick-up ampere when it was classified. A guaranteed value has a tolerance of $\pm 2A$, and consequently the reed switch with this designation pick-up ampere between 08A and 22A.

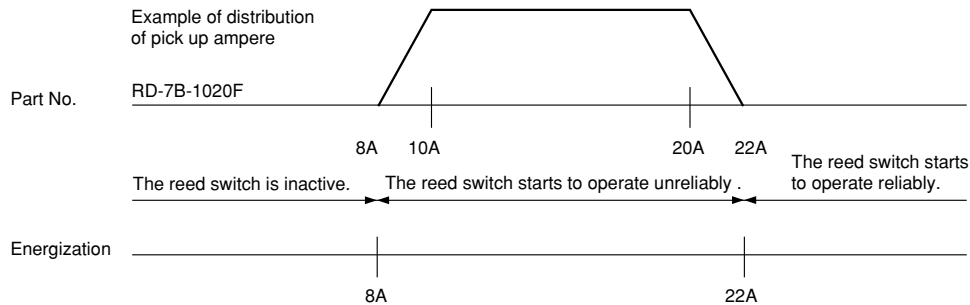

Fig. 9 Example of sensitivity distribution of reed switch



- All specifications in this catalog and production status of products are subject to change without notice. Prior to the purchase, please contact NEC TOKIN for updated product data.
- Please request for a specification sheet for detailed product data prior to the purchase.
- Before using the product in this catalog, please read "Precautions" and other safety precautions listed in the printed version catalog.

Contact point protection circuit

To improve reliability of the reed switch and proximity switch, use the contact point protection circuit shown below for use with an inductive load or with a load applied with surge current.

(1) Inductive Load

When an inductance (e.g., a coil, an electromagnetic relay, or a motor) is used as load, a back electromotive force of several hundred volts (energy stored in the inductance) arises when the contacts are opened, which results in considerable decrease in contact life (the same result arises even when a resistive load is used with a high voltage or a large current). Fig. 10 shows circuits for protecting the reed switch from the back electromotive force.

● Contact Protecting Circuit Using CR

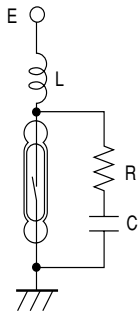

- $C = I^2/10$ (μF)
- $R = \text{Approx. } \frac{E}{10 \times I^{(1+50/E)}} (\Omega)$

● Contact Protecting Circuit Using Varistor

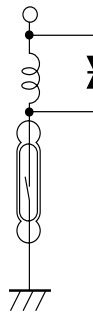

● Contact Protecting Circuit Using Diode

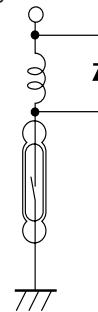

- Diode has a withstand voltage of more than EV.
- Forward-direction current
- Approximately $5E/\text{load coil resistance (A)}$

Fig. 10

(2) Capacitive Load

When a capacitor is used as load, a rush current flows as a result of the charging and discharging action of the capacitor when the contacts are closed, thereby making it impossible for the contacts to open. Fig. 11 shows a circuit for protecting the reed switch from the rush current.

● Contact Protecting Circuit Using R

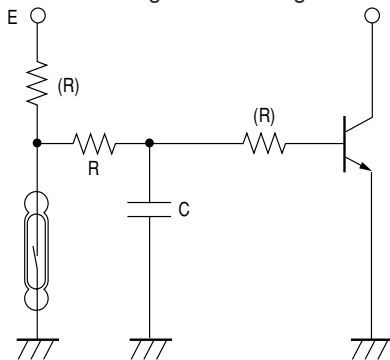

R : The value at which a rush current becomes smaller than the maximum current for opening/closing a reed switch

Fig. 11



(3) Lamp Load

Tungsten is commonly used for a lamp filament. The tungsten lamp is characterized in that the resistance of the lamp, which is small when the lamp initially lights up, progressively increases and becomes stable at a stationary electric current. If the tungsten lamp is actuated using the reed switch, a rush current (5 to 10 times as large as stationary electric current) flows into the lamp immediately after the lamp has lit up, which may cause the contacts to be fused or stuck to each other. Fig. 12 shows a circuit with a protecting resistor R for preventing the reed switch contacts from being fused or stuck to each other. If the use of the protecting resistor is not desired, please use the RD-8N reed switch.

● Contact Protecting Circuit Using R

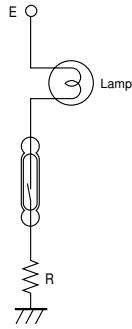

● Contact Protecting Circuit Using R

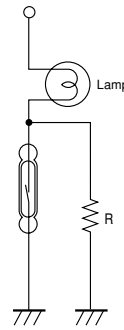

R : The value at which a rush current becomes smaller than the maximum current for opening/closing a reed switch

Fig. 12

(4) Wiring Capacitive Load

If the contacts and load are connected together through a long wire or cable, a rush current flows by means of stray capacitance of the wire or cable when the contacts are closed, which significantly influences contact life. Fig. 13 shows a circuit with resistance or inductance for preventing the flow of the rush current.

● Contact Protecting Circuit Using R or L

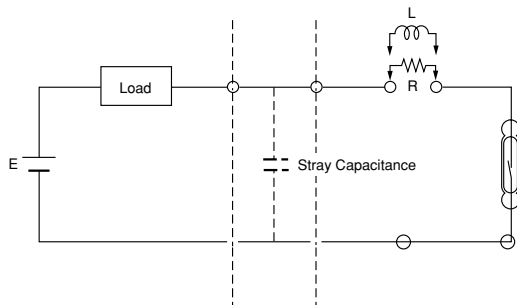

R : The value at which a surge current generally becomes smaller than the maximum current for opening and closing a reed switch
L : Inductance of around 1 to 10 μ H

Fig. 13

Concerning Ultrasonic

(1) Ultrasonic Cleaning

Avoid, in principle, ultrasonic cleaning of the reed switch and proximity switch per se or after mounted on a printed wiring board, since ultrasonic wave may degrade the sensitivity (the distance of the contact point) or cause cracks in the sealing portion of the glass tube.

(2) Ultrasonic Welding

Avoid, in principle, also ultrasonic welding of the reed switch and proximity switch similarly to the ultrasonic cleaning, since ultrasonic wave may degrade their performances.



● All specifications in this catalog and production status of products are subject to change without notice. Prior to the purchase, please contact NEC TOKIN for updated product data.
● Please request for a specification sheet for detailed product data prior to the purchase.
● Before using the product in this catalog, please read "Precautions" and other safety precautions listed in the printed version catalog.

Twin Reed Switch Type Safing Sensor High Stand Type : TMSD-H**51D



Outline

NEC TOKIN has produced two-element compact and high-performance reed switch type safing sensors responding to current needs in which special emphasis is placed on safety.

Features

- High density mounting on board
- High water-proof
- High resistance to G-noise to (except G-detection)

Applications

- SRS air bag systyem
- Seat belt pre-tensioner

Markings

TMSD-H2251D
 └── Starting G (started at 2.2 G)

Specifications

Electrical operating characteristics and mechanical characteristics

Item	Standard	Remarks
Intercontact withstand voltage	min. 200V	—
Switching voltage	max. 40V	—
Switching current	max. 7A	—
Carry current	max. 20A	—
Contact resistance	max. 150mΩ	When 100mA is applied
Insulation resistance	min. 10MΩ	Applied voltage of 100VDC
Operating time	max. 16.0ms	7.2G-20ms (Half sine wave)
ON-holding time	min. 26.5ms	7.2G-20ms (Half sine wave)
Retention temperature	-40~+100°C	—
Operating temperature	-30~+80°C	—



- All specifications in this catalog and production status of products are subject to change without notice. Prior to the purchase, please contact NEC TOKIN for updated product data.
- Please request for a specification sheet for detailed product data prior to the purchase.
- Before using the product in this catalog, please read "Precautions" and other safety precautions listed in the printed version catalog.

When using our products, the following precautions should be taken.

- (1) Safety designing of an apparatus or a system allowing for failures of electronic components used in the system

In general, failures will occur in electronic components at a certain probability. NEC TOKIN makes every effort to improve the quality and reliability of electronic component products. However, it is impossible to completely eliminate the probability of failures. Therefore, when using NEC TOKIN's electronic component products, systems should be carefully designed to ensure redundancy in the event of an accident which would result in injury or death, fire, or social damage, to ensure the prevention of the spread of fire, and the prevention of faulty operation. (For details about failure mode, see "Precautions for Use".)

- (2) Quality level of various kinds of parts, and equipment in which the parts can be utilized
Electronic components have a standard quality level unless otherwise specified.

NEC TOKIN classifies the level of quality of electronic component products into three levels, in order from a lower level, a standard quality level, a special quality level, and a custom quality level in which a customer individually specifies a quality assurance program. Each of the quality levels has recommended applications.

If a user wants to use the electronic parts having a standard quality level in applications other than the applications specified for the standard quality level, they should always consult a member of our company's sales staff before using the electronic parts.

Standard quality level : Computers, office automation equipment, communications equipment, measuring instruments, AV equipment, household electrical appliances, machine tools, personal equipment, industrial robots

Special quality level : Transportation equipment (automobiles, railways, shipping, or the like), traffic signals, disaster prevention/crime prevention systems, a variety of safety devices, and medical equipment which is not directly intended for life-support purposes

Custom quality level : Equipment for airplanes, aerospace equipment, nuclear power control systems, and medical equipment, apparatus or system for life-support purposes

Unless otherwise shown, the quality level of NEC TOKIN's electronic component products included in documents such as catalogues, data sheets or data books is the standard quality level.

- (3) This manual is subject to change without notice.

The contents of this manual are based on data which is correct as of July 2007, and they may be changed without notice. If our products are used for mass-production design, please enquire consult with a member of our company's sales staff by way of precaution.

- (4) Reprinting and copying of this manual without prior written permission from NEC TOKIN Corporation are not permitted.

- (5) Industrial property problems

In the event any problems associated with industrial property of a third party arising as a result of the use of our products, NEC TOKIN assumes no responsibility for problems other than problems directly associated with the constitution and manufacturing method of the products.

- (6) Export Control

For customers outside Japan

NEC-TOKIN products should not be used or sold for use in the development, production, stockpiling or utilization of any conventional weapons or mass-destructive weapons (nuclear weapons, chemical or biological weapons, or missiles), or any other weapons.

For customers in Japan

For products which are controlled items subject to the ' Foreign Exchange and Foreign Trade Law ' of Japan, the export license specified by the law is required for export.



- All specifications in this catalog and production status of products are subject to change without notice. Prior to the purchase, please contact NEC TOKIN for updated product data.
- Please request for a specification sheet for detailed product data prior to the purchase.
- Before using the product in this catalog, please read "Precautions" and other safety precautions listed in the printed version catalog.